

**GENERAL DYNAMICS**  
SATCOM Technologies

**4096-225**  
**REVISION J**  
**April 19, 2016**

**Assembly Manual**

**3.4M & 3.7M**  
**Az/EI Truss Mount**

**General Dynamics SATCOM Technologies**  
**1700 Cable Drive NE**  
**Conover NC 28613 USA**  
**Phone 770-689-2040**  
**[www.gdsatcom.com](http://www.gdsatcom.com)**

## 3.4M & 3.7M Az/EI Truss Mount

J	Revise to Conover Address	4/19/16	RAH
I	Revise Logo	3/24/09	RAH
H	Revised Address	1/10/02	CLT
G	Redesign & update. Removed 3.0M antenna	9/11/97	PGW
F	Pol was pole	7/11/97	PGW
E	Revised Hdw Qty On Pg 28 Per Ecn #1709 And Added Revision Page	08/04/94	RF
-	ORIGINAL RELEASE	11/03/92	R FRYE
<b>REV.</b>	<b>DESCRIPTION</b>	<b>DATE</b>	<b>APPROVED</b>

**ASSEMBLY MANUAL****Table Of Contents**

<u>Section</u>	<u>Title</u>
1.0	General Information
1.1	Unpacking & Inspection
1.2	Mechanical Installation Tools
1.3	Site Selection
1.4	Foundation Requirements
2.0	Reflector And Support Structure Assembly
2.1	Reflector and Support Structure Part List
2.2	Reflector Pre- Assembly
2.3	Reflector Assembly
2.4	Brace Mount Brackets
2.5	Support Structure Assembly
3.0	Reflector Installation
3.1	Reflector Mount Part List
3.2	Canister / Elevation Rod Assembly
3.3	Reflector Positioning
4.0	Feed Installation
4.1	Feed Horn Assembly
4.2	Feed System Part List
4.3	Feed Support Assembly
4.4	Feed Installation
4.5	Feed Cover Installation
5.0	Antenna Alignment And Tuning
5.1	Elevation Adjustment
5.2	Azimuth Adjustment
5.3	Fine Tuning
5.4	Reflector Fine Adjustment

## **SECTION 1 GENERAL INFORMATION**

### **1.1 UNPACKING AND INSPECTION**

1. **UNPACKING & INSPECTION** - The antenna containers should be unpacked and inspected at the earliest date to ensure that all material has been received and is in good condition. A complete packing list for each major component is supplied.
  
2. **FREIGHT DAMAGE** - Any damage to materials while in transit should be immediately directed to the freight carrier. He will instruct you on the matters regarding any freight damage claims.
  
3. **MATERIAL - MISSING OR DAMAGED** - Any questions regarding missing or damaged materials that is not due to freight carrier should be directed to General Dynamics Customer Service Department at:

**General Dynamics SATCOM Technologies**  
**1700 Cable Drive NE**  
**Conover NC 28613 USA**  
**Phone 770-689-2040**  
**[www.gdsatcom.com](http://www.gdsatcom.com)**

**1.2 MECHANICAL INSTALLATION TOOLS**

HARDWARE SIZE	SAE WRENCH SIZE	METRIC WRENCH SIZE	MAXIMUM REC. TORQUE
# 6 SCREW	5/16"	8 mm	8 in-lbs
1 / 4"	7 / 16"	11 mm	49 in-lbs
3 / 8"	9 / 16"	14 mm	15 ft-lbs
1 / 2"	3 / 4"	20 mm	35 ft-lbs
5 / 8"	15 / 16"	24 mm	70 ft-lbs
3 / 4"	1- 1 / 8"	28 mm	220 ft-lbs

Also recommended for installation:

Adjustable Wrench 10"  
Ratchet ( 3 / 8" drive)  
Inclinometer  
Compass  
8' ft Ladder  
Gloves

**1.3 SITE SELECTION**

In order to achieve maximum performance of your antenna system, it is important to select the correct location for the antenna. The following guidelines should be observed when selecting a site for the installation.

1. The line of site to the satellite should be clear of any obstructions, such as trees or buildings.
2. The site should be relatively flat and level for ease of installation and access to the antenna.
3. The site should be checked for underground obstruction, such as buried cables or pipes.
4. All local building codes should be adhered to (i.e. grounding, foundation requirements, zoning rules, setbacks, etc.).

**1.4 FOUNDATION REQUIREMENTS**

General Dynamics recommended foundation for the antenna system is shown in figure 1. however, each installation must be tailored to the specific requirements of the site. It may be necessary to contact a local engineer or building department for foundation design or approval at any particular site.

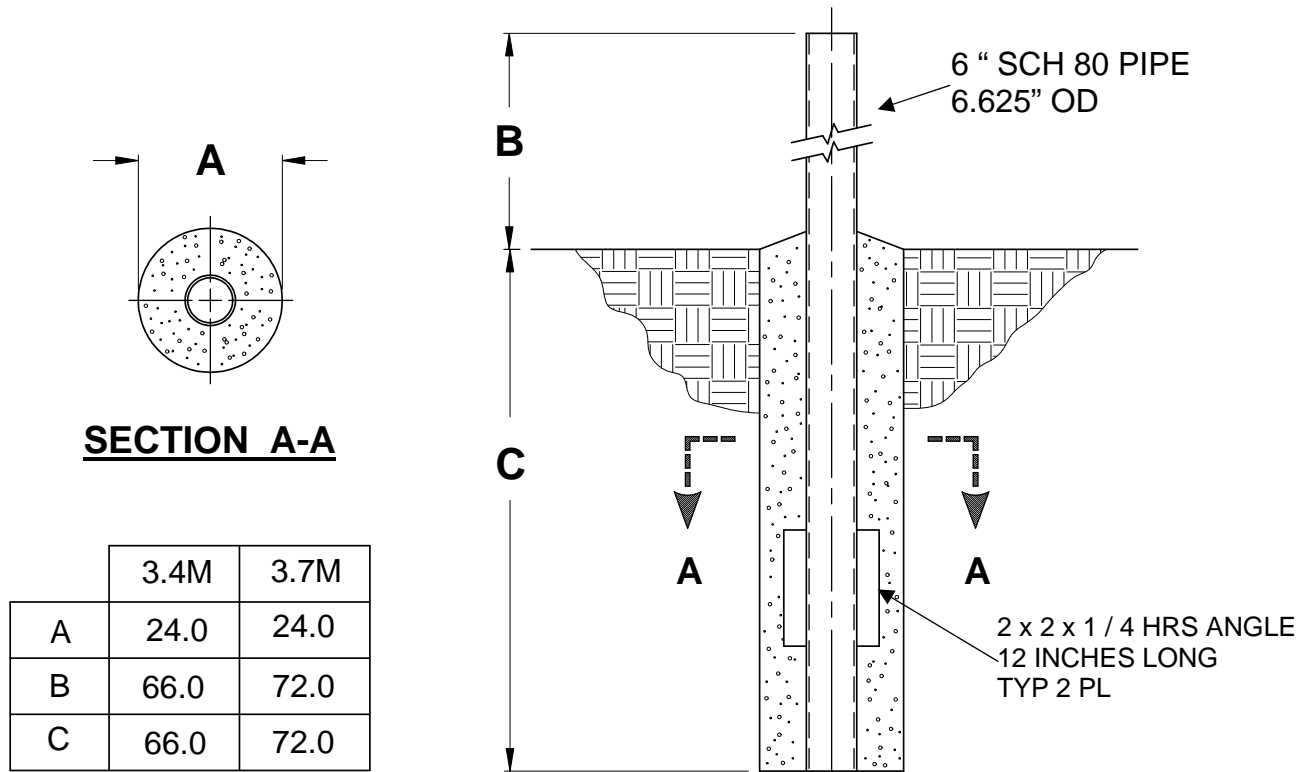

**FIGURE 1.**



**NOTES:**

1. 2 x 2 x 1/4 HRS Angle and schedule 40 pipe should conform with ASTM A36 and ASTM A53 Type E and S Grade B.
2. All concrete should conform to building code standards and have a minimum compressive strength of 3000 PSI at 28 days. (Per ACI-318-77)
3. Soil bearing capacity should be no less than 2000 PSF.
4. Concrete should be poured against undisturbed soil.
5. Allow concrete 24 hours set time before installation of antenna.
6. The antenna should be properly grounded to meet applicable local codes.
7. Minimum depth as shown or extend to local frost line.

General Dynamics DOES NOT REPRESENT OR WARRANT THAT ANY PARTICULAR DESIGN OR SIZE OF FOUNDATION IS APPROPRIATE FOR ANY LOCALITY OR EARTH STATION INSTALLATION

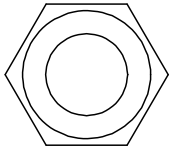
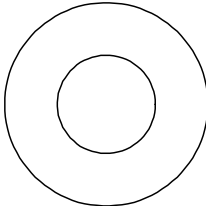
**SECTION 2 REFLECTOR AND SUPPORT STRUCTURE ASSEMBLY**

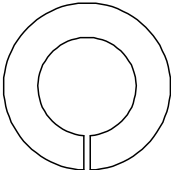
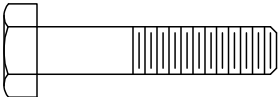
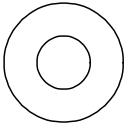
<b>REFLECTOR AND SUPPORT STRUCTURE PARTS LIST TABLE 2.1</b>				
<b>ITEM</b>	<b>PART NO.</b>	<b>DESCRIPTION</b>	<b>QTY 3.4M</b>	<b>QTY 3.7M</b>
1	0179-142 0179-261	REFLECTOR PETAL - W / HOLE REFLECTOR PETAL - W / HOLE	4	4
2	0179-141 0179-260	REFLECTOR PETAL - W/O HOLE REFLECTOR PETAL - W/O HOLE	4	4
3	0217-072 0217-073	FEED SUPPORT CLEVIS FEED SUPPORT CLEVIS	4	4
4	0490-301	CENTER HUB	1	1
5	0156-808	CENTER PLATE	1	1
6	0211-404 0211-481	REFLECTOR SUPPORT BRKT. REFLECTOR SUPPORT BRKT.	8	8
7	0225-405	SUPPORT BRACE - LONG	8	8
8	0225-406	SUPPORT BRACE - SHORT	8	8
9	8104-007	1 / 2" HEX NUT	8	8
				
10	8201-043	1 / 2" FLATWASHER	8	8
				

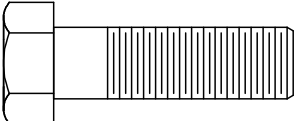
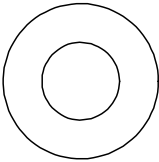
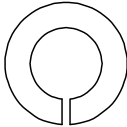
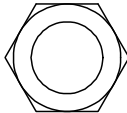
PARTS LIST - CONTINUED				
ITEM	PART NO.	DESCRIPTION	QTY 3.4M	QTY 3.7M
11	8202-043	1 / 2" LOCKWASHER 	4	4
12	8030-010	1 / 4" - 20 x 1.25 BOLT 	6	6
13	8201-040	1 / 4" FLATWASHER 	6	6
14	8202-040	1 / 4" LOCKWASHER 	6	6
15	8202-010	3 / 8" -16 x 1.25 BOLT 	72	96
16	8201-042	3 / 8" FLATWASHER 	144	192
17	8202-042	3 / 8" LOCKWASHER 	72	96
18	8102-007	3 / 8" HEX NUT 	72	96



**NOTE:** Assembly of the reflector should be on as level a surface as possible to prevent warping or misalignment of the reflector's parabolic shape during assembly. Any loss of contour may affect the antenna's signal quality. If a level surface is not available, refer to section 5.4 for tips on how to check the reflector shape and correct it, if necessary.

## 2.2 REFLECTOR PRE-ASSEMBLY

The reflector consists of eight interchangeable petals of compression molded glass-fiber reinforced material. This material is very strong, yet lightweight and easy to handle. The reflector will possess a very accurate parabolic shape when properly assembled and will retain its shape for years under harsh environmental conditions. The microwave reflective surface is provided by a fine mesh screen that lies just beneath the molded surface of the petals.

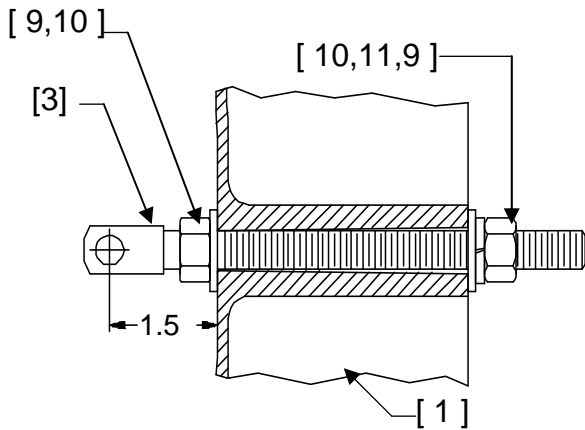

**3.4M**

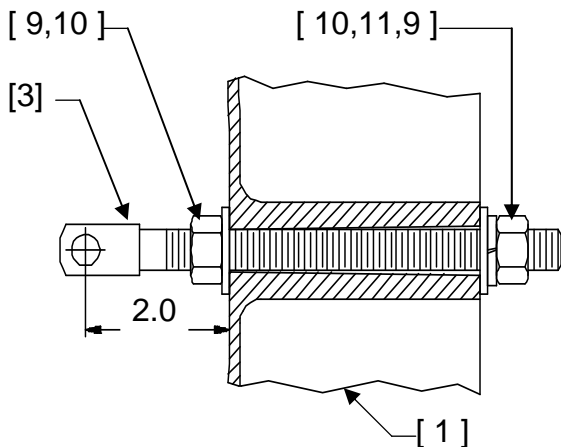

- A) Identify the reflector petals and parts of the reflector support structure according to the parts list. We recommend that you hi-lite the column for your specific antenna.
- B) Note that four of the petals (item 1) have a 1 / 2" hole thru the center. These holes are for the feed clevises. Pre assemble these four petals as follows.
- C) Run the 1 / 2" nut (item 9) up the threads of the clevis (item 3), and place a 1 / 2" flatwasher (item 10) against the nut. Adjust the nut until the distance from the far side of the washer and the center of the clevis hole is 2" for the 3.7M and 1.5" for the 3.4M
- D) From the face of the petal, insert the clevis assembly thru the hole in the center of the petal. Secure with 1 / 2" hardware. Tighten these nuts hand tight at this time.

2.3 REFLECTOR 3.7M ASSEMBLY

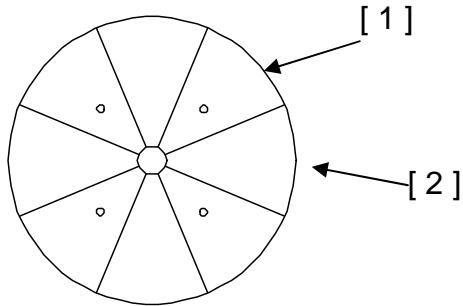

**STEP 1:**

When assembling the reflector petals (items 1,2), note the orientation of the petals. Every other petal contains a feed clevis.

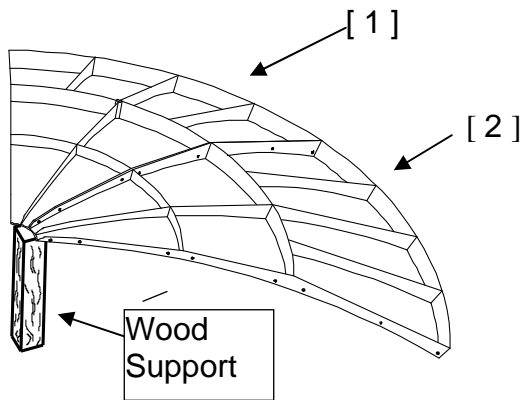

**STEP 2:**

Place two petals rim down on a level surface with their flanges next to each other. A wooden support (23.25" long for the 3.4M and 24" for the 3.7M), such as a 4x4, will help support the narrow ends of the petals.

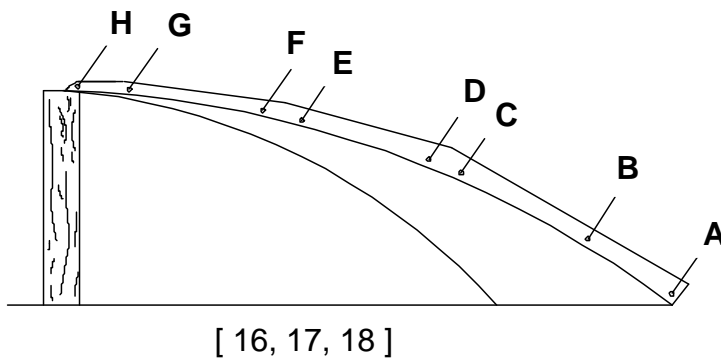

**STEP 3:**

- A) Begin the assembly at the flange with 3 / 8" hardware (items 15, 16, 17, 18), in holes A, B, C, etc. Note that this illustration shows a 3.7M petal which has eight holes. The 3.4M petal only has five holes.
- B) Do not fully tighten bolts until instructed. You may notice that the hardware fits snugly in the holes. This is to assure the accurate alignment of the petals. If necessary, gently tap or thread the bolts into the holes.

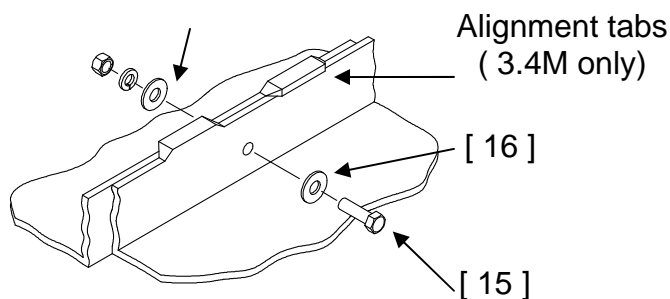

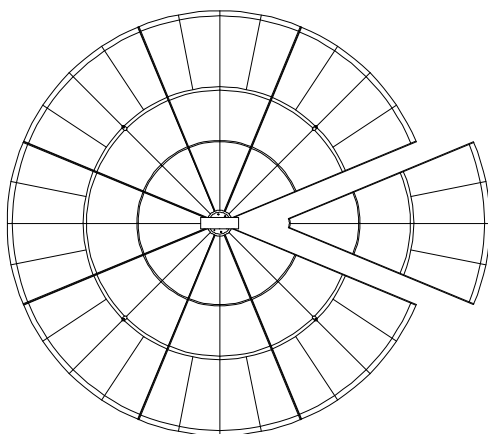
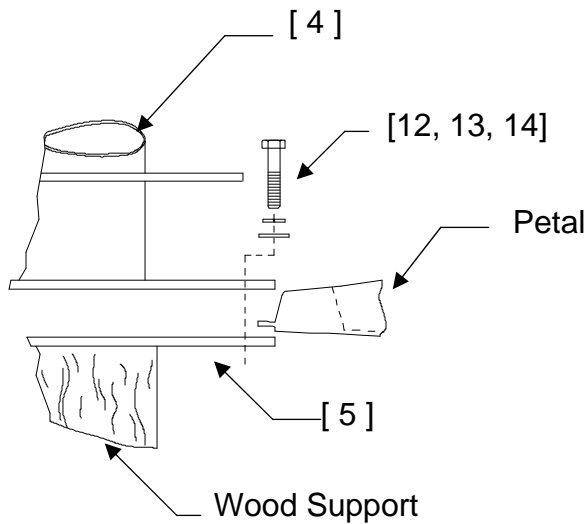
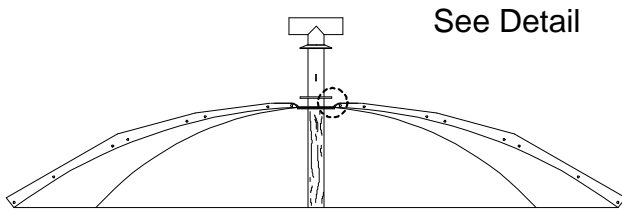

**STEP 4:**

- A) Continue assembling additional petals as above. The wooden support should be moved as necessary to support the weight of the petals being assembled. Before installing the last petal, place the center plate (item 5) on top of the wooden support - underneath the center of the reflector - and attach the center hub (item 4) on top with 1 / 4" hardware (items 12, 13, 14). Leave hardware loose enough to rotate hub.
- B) Place the last petal in position, insuring that the lip on its inner edge is located between the center hub and plate. Attach this petal to the adjacent petal at holes A and B. At this time, the reflector is strong enough to sustain the weight of the installer to place the bolts in holes C, D, E etc. Be sure to step only on the ribs, not on the surface in between.
- C) Now tighten all reflector bolts. Before tightening, check to be sure that all the petals are aligned properly. It may be necessary to adjust one petal in or out (radially) until the rim is flush. Also check up and down alignment. It is possible to lift the reflector slightly to feel the front surface, making sure that it is flush. Tighten all A bolts first. Next tighten all B bolts, then C, then D, etc. Note: Before tightening the last set of reflector bolts, the ones closest to the hub, check to make sure that the lip on the inner edges of all petals are located between the center plate and the center hub plate.

2.4 BRACE MOUNT BRACKETS FOR 3.4M, AND 3.7M

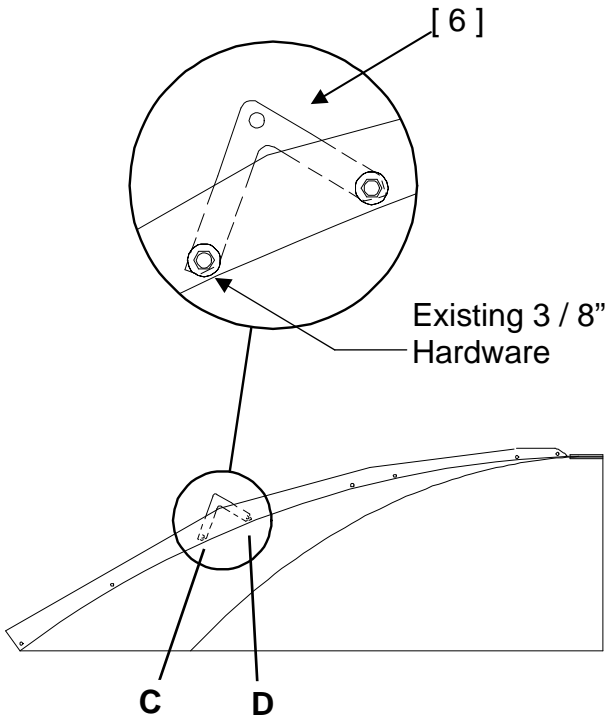

3.7M

Attach the reflector support brackets (item 6) to the reflector at locations C and D at the **left side** of all eight petal seams. Be sure that the shorter, more pointed leg of each bracket is toward the reflector center. Use the existing 3/8" hardware. Do not tighten this hardware until instructed.

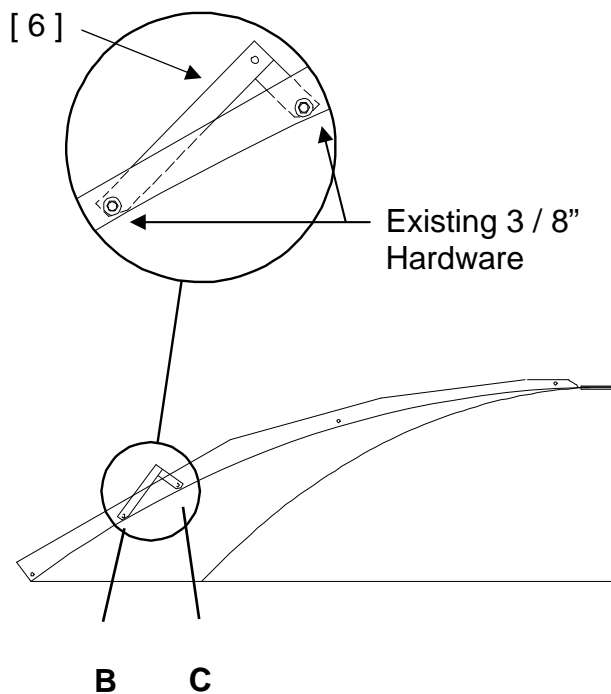

3.4M

Attach the reflector support brackets (item 6) to the reflector at locations B and C at the **left side** of all eight petal seams. Be sure that the shorter, more pointed leg of each bracket is toward the reflector center. Use the existing 3/8" hardware. Do not tighten this hardware until instructed.

## 2.5 SUPPORT STRUCTURE ASSEMBLY

### STEP 1:

Rotate the Center Hub until the elevation tab is centered over a petal without a feed clevis.

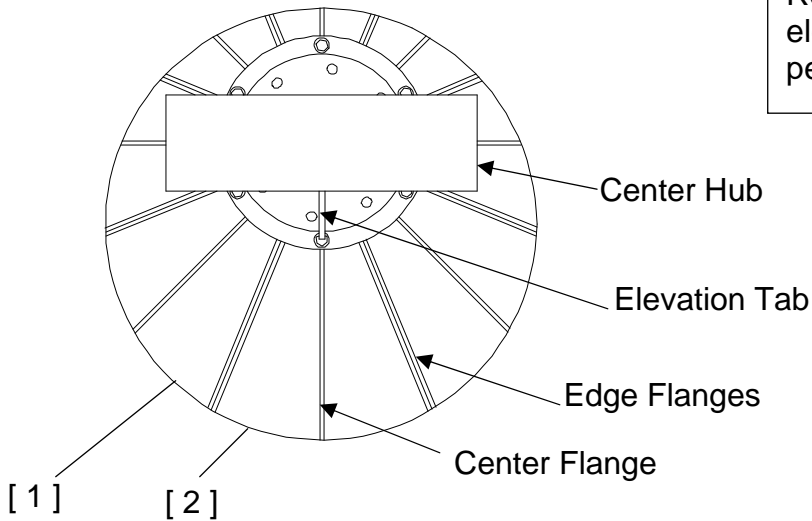

### STEP 2:

Attach the chamfered end of the long support brace (item 7) to the underside of the upper ring with 3 / 8" hardware (items 15, 16, 17, 18). Do not tighten.

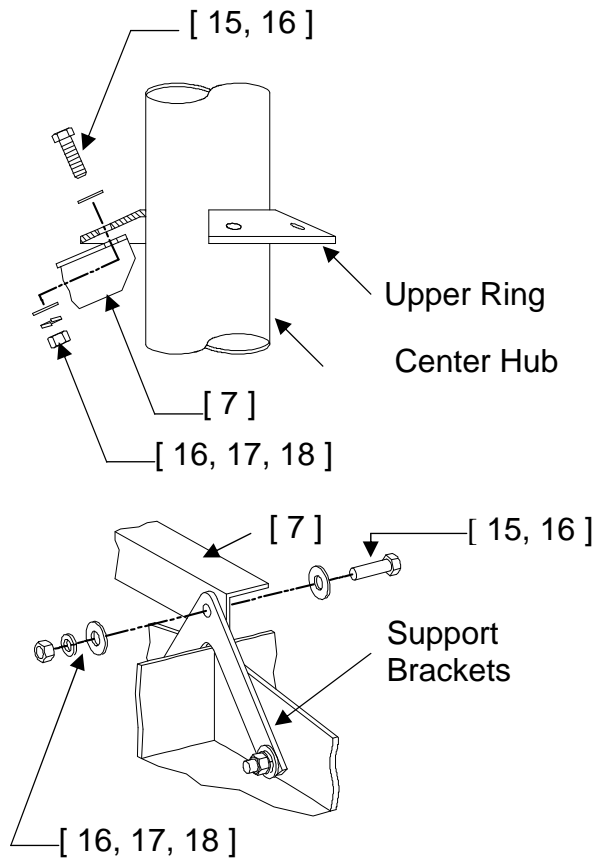

### STEP 3:

- A) Position the remaining end of the long support brace (item 7) to the right of the support bracket .
- B) Attach brace with 3 / 8" hardware (items 15, 16, 17, 18). Do not tighten until instructed.
- C) Attach the remaining long support braces from each of the support brackets to the center hub in the same manner.

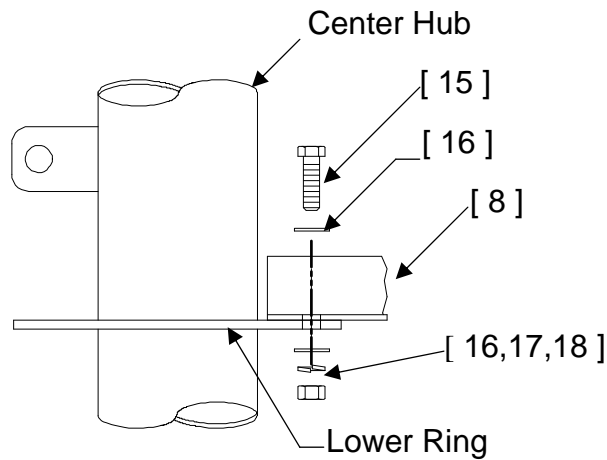

**STEP 4:**

Attach one end of the short support brace (item 8) to the lower ring on the center hub with 3 / 8" hardware (items 15, 16, 17, 18). Do not tighten until instructed.

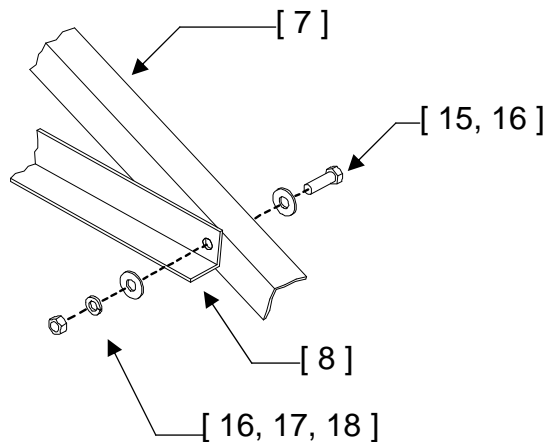

**STEP 5:**

A) Attach the other end of the short support brace (item 8) to the left side of the long brace (item 7) with 3 / 8" hardware (items 15, 16, 17, 18). When all braces are attached, begin tightening as follows.

B) Be sure the reflector is laying flat, as after tightening the reflector structure, its shape will be fixed. Center in the center hub by tightening the 1 / 4" bolts to the center plate.

Next, tighten all the hardware that attaches the support brackets to the reflector. Tighten the outermost bolts securing the long braces to the support brackets all around. Now tighten the bolts connecting the long braces to the center hub all the way around.

Next tighten the hardware connecting the short brace to the long brace all around. Finally tighten the hardware securing the short braces to the center hub. The assembly of the reflector and the support structure is now complete.

**SECTION 3 REFLECTOR INSTALLATION**

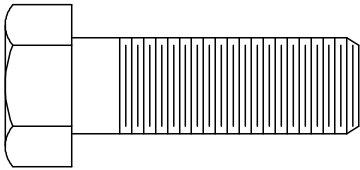
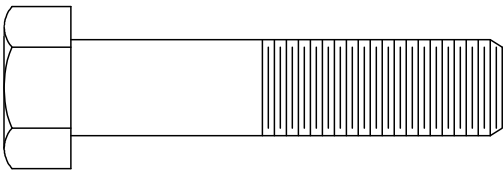
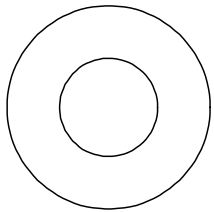
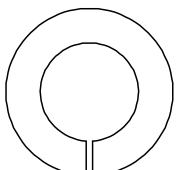
REFLECTOR MOUNT PARTS LIST TABLE 3.1			
ITEM	PART NO.	DESCRIPTION	QTY
1	0490-125	CANISTER	1
2	0168-085	ELEVATION ADJUSTMENT BLOCK	1
3	0490-100	ELEVATION STRUT - INNER	1
4	0490-306	ELEVATION STRUT - OUTER	1
5	8403-008	1/2 -13 x 4.00 U-BOLT	2
6	8317-106	5/8" x 1.50 SQ. HD BOLT	6
7	8033-012	1/2 -13 x 1.50 BOLT 	2
8	8033-018	1/2-13x 2.25 BOLT 	1
9	8201-030	1/2 FLATWASHER 	8
10	8202-043	1/2 LOCKWASHER 	7

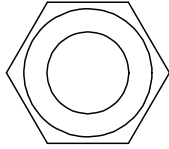
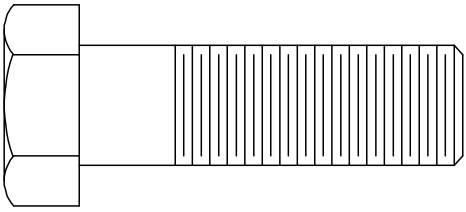
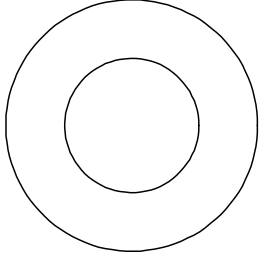
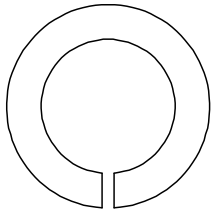
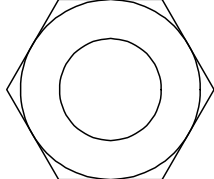
PARTS LIST - CONTINUED			
ITEM	PART NO.	DESCRIPTION	QTY
11	8104-007	1/2-13 HEX NUT 	5
12	8034-016	5/8-11 x 2.00 BOLT 	1
13	8201-039	5/8 FLATWASHER -NARROW 	2
14	8202-044	5/8 LOCKWASHER 	1
15	8105-007	5/8 - 11 HEX NUT 	7

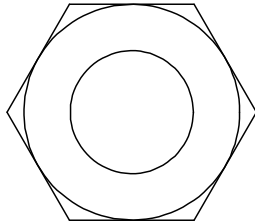
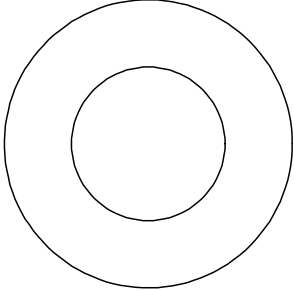

PARTS LIST - CONTINUED			
ITEM	PART NO.	DESCRIPTION	QTY
16	8106-007	3/4 - 10HEX NUT	2
			
17	8201-047	3/4 WASHER	2
			

**NOTE:** At least three persons are required for the installation of the antenna on the mast. After the reflector is positioned on the canister, two can steady the reflector while the other secures it with the u-bolts.

### 3.2 CANISTER & ELEVATION ASSEMBLY

#### STEP 1:

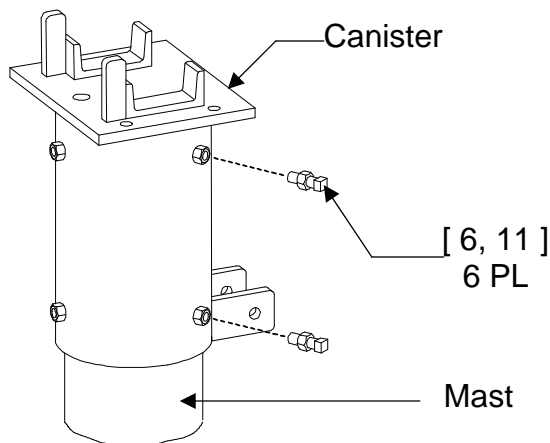

Run a 1/2" hex nut (item 11) onto each square head bolt (item 6). Then insert them into the canister, only a few turns, so that the bolts do not extend into the canister. Position the canister on the mast and insure that it is seated all the way down on the mast pipe and that it can rotate freely.

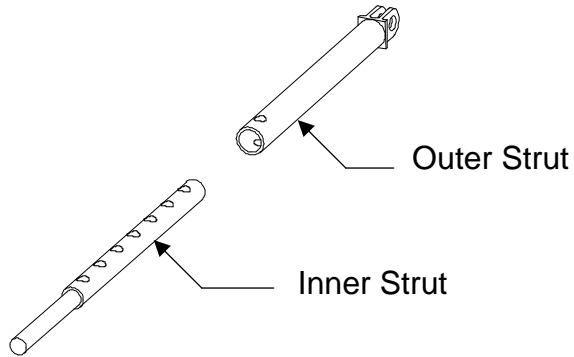

**STEP 2:**

Assemble the elevation rod by inserting the inner strut (item 3) all of the way into the outer strut (item 4)

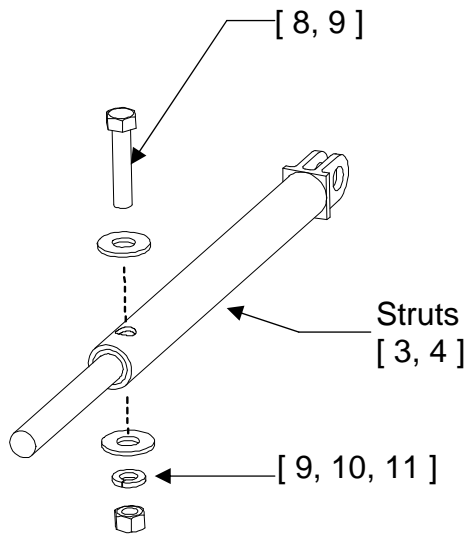

**STEP 3:**

Secure the struts with 1/2" hardware (items 8, 9, 10, 11)

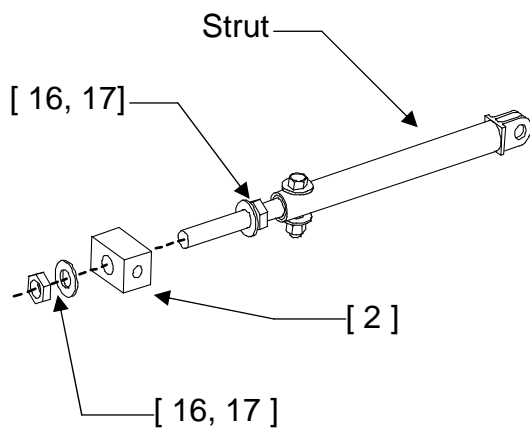

**STEP 4:**

- A) Run one 3/4" nut (item 16) up the threads of the inner strut and follow with one 3/4" washer (item 17).
- B) Insert the strut through the elevation block (item 2) and secure with 3/4" nut and washer.

**3.3 REFLECTOR POSITIONING**

**STEP 1:**

Bring the completed reflector assembly to the pedestal and locate it about 1-1/2 to 2 feet away from the mast. Make sure that the elevation tab on the canister is pointing towards the mast. Use the reflector carton (or similar object) as a rest for under the edge of the reflector. Orient the reflector so that the cross-tube of the center hub is perpendicular to mast.

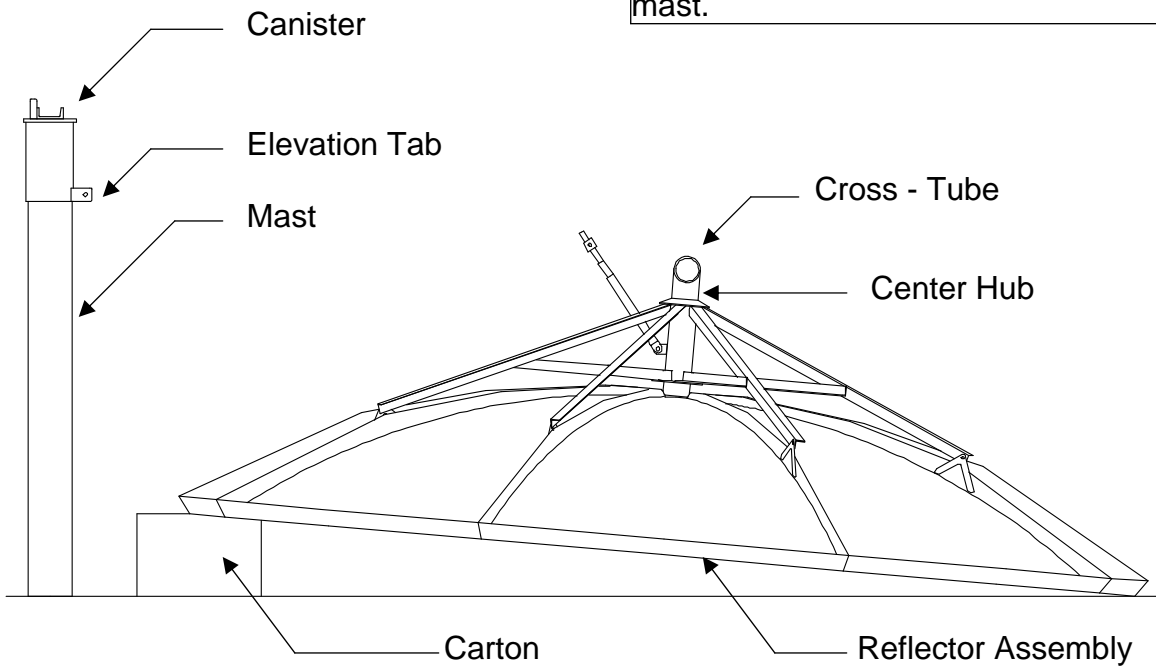

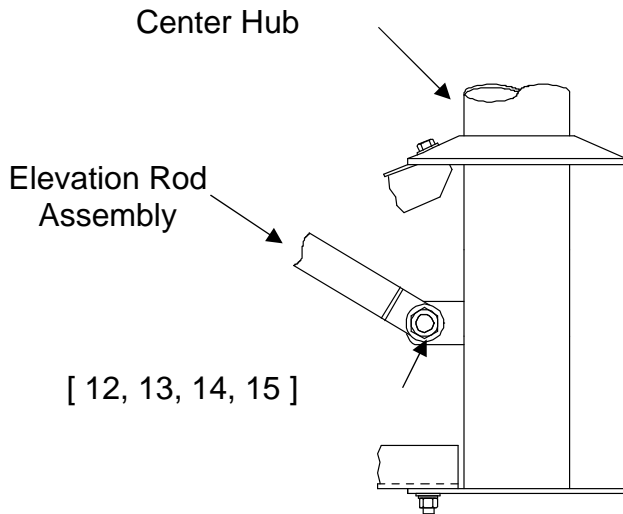

**STEP 2:**

Attach the elevation rod assembly to the elevation tab on the center hub with 5/8" hardware (items 12, 13, 14, 15) as shown. Have the two U-bolts and 1/2" hardware close at hand.

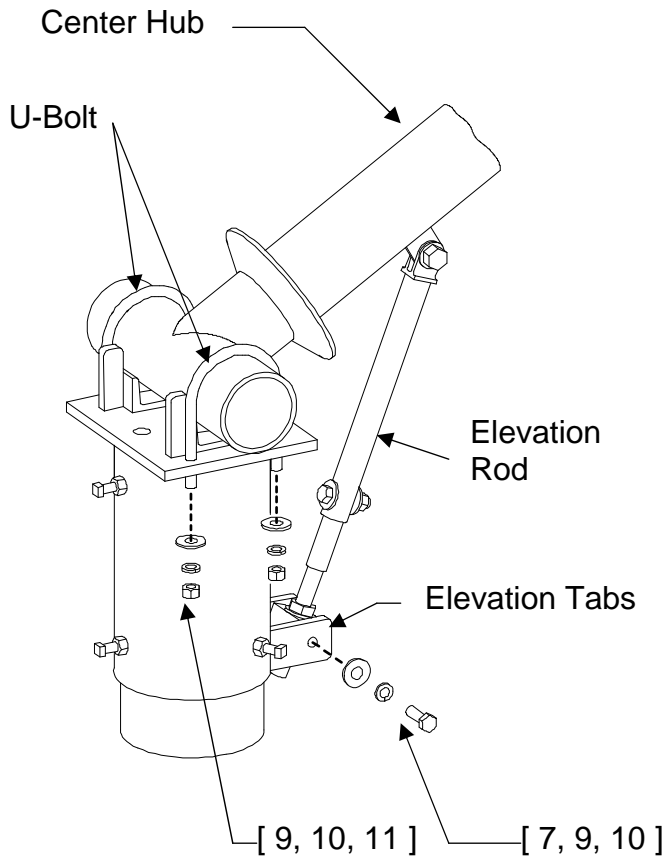

**STEP 3:**

- A) Swing the reflector up until the cross tube can be placed in the cradle of the canister.
- B) Raise the reflector's lower edge until two persons can steady the reflector in the cradle. Now the other installer can secure the reflector to the canister with the U-bolts and 1/2" hardware (items 5, 9, 10, 11). Tighten hardware to allow reflector to rotate in elevation.
- C) Raise or lower the reflector until you can place the elevation adjustment block (item 2) between the two tabs on the canister and secure with two 1/2" bolts, flatwashers and lockwashers (items 7, 9, 10). Do not tighten these bolts until section 5.1.

**SECTION 4**      **FEED INSTALLATION****4.1**    **FEED HORN ASSEMBLY****Ku-BAND FEED**

SINGLE POL - Coat the o-ring (item #2) with the silicone grease from the capsule provided and place it in the feed horn o-ring groove. Place the square adapter (item #3) on the feed horn flange and line up the four hole pattern in the adapter with four of the eight holes in the feed horn flange. (Note that the adapter will only line up one way.) Place the LNB (customer provided) on the adapter so that the holes in the LNB line up with the feed/adapter holes and secure with four screws (item #4). See figure 1. Tighten securely.

<b>Ku-BAND - SINGLE POL - PARTS LIST</b>			
<b>ITEM #</b>	<b>PART #</b>	<b>DESCRIPTION</b>	<b>QUANTITY</b>
<b>1</b>	<b>0183-277</b>	<b>FEED HORN ASSEMBLY</b>	<b>1</b>
<b>2</b>	<b>0198-120</b>	<b>O-RING</b>	<b>1</b>
<b>3</b>	<b>0202-067</b>	<b>TRANSITION ADAPTER</b>	<b>1</b>
<b>4</b>	<b>8300-017</b>	<b>#6-32 x 7/8" SS STD</b>	<b>6</b>
<b>5</b>	<b>8200-010</b>	<b>#6 LOCKWASHER</b>	<b>6</b>

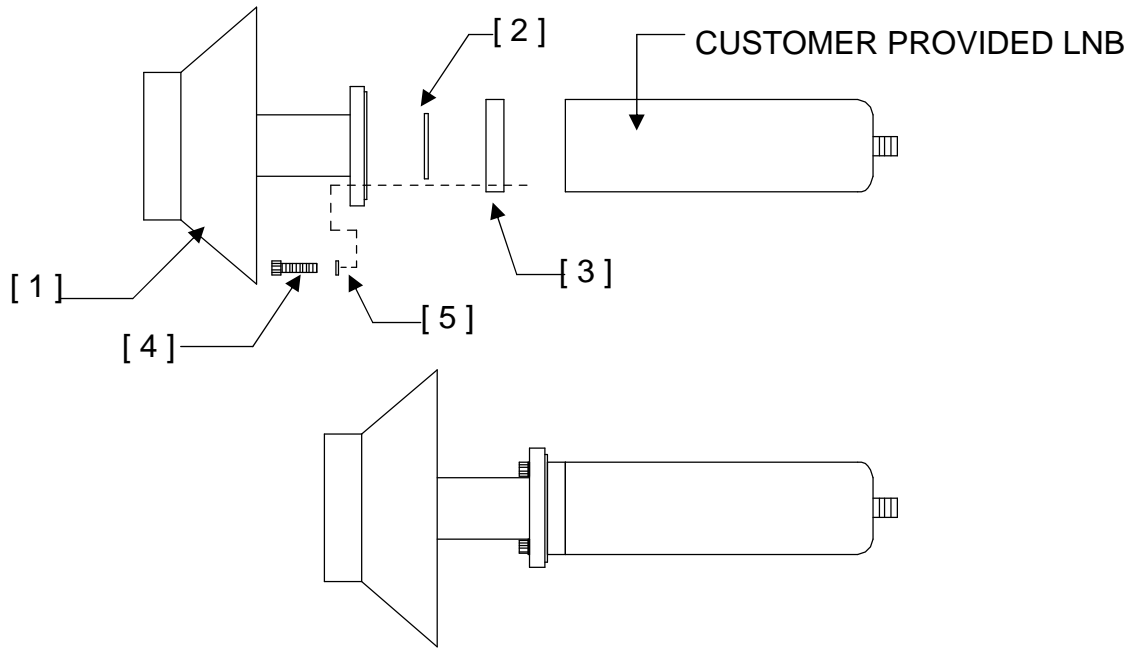
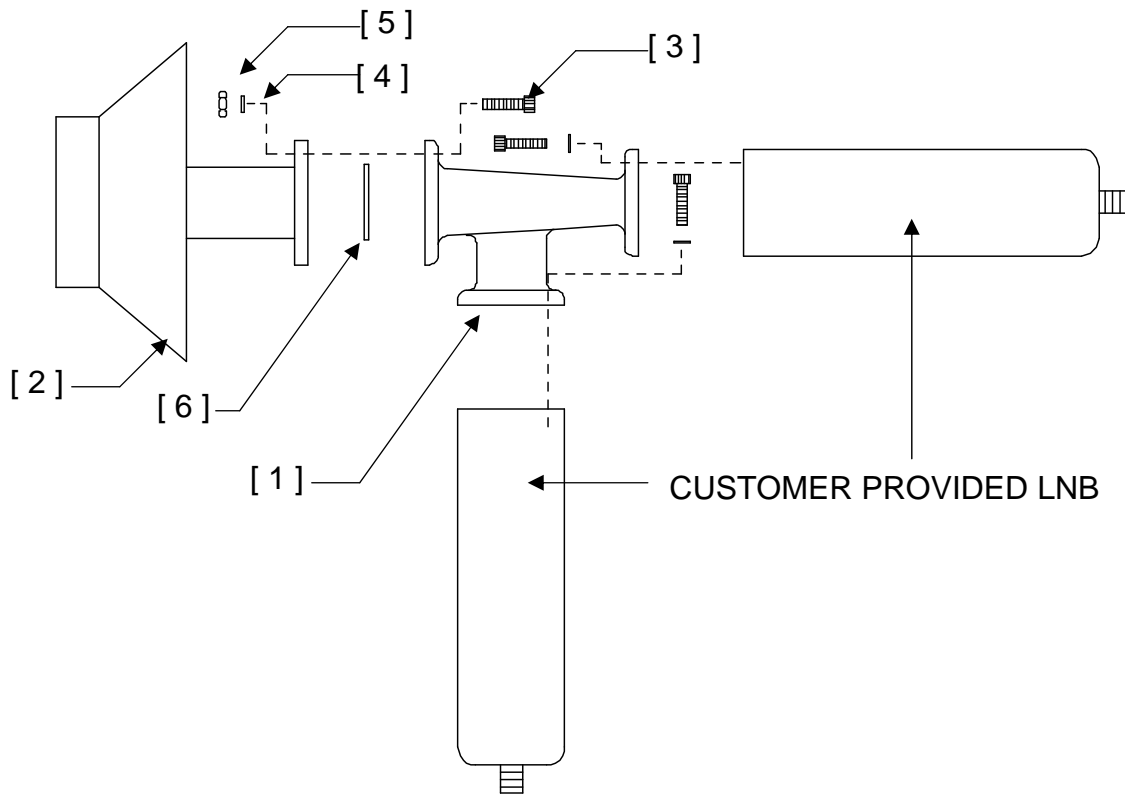

FIGURE 1.

**Ku-BAND FEED**

DUAL POL - Coat the o-ring (item #6) with the silicone grease from the capsule provided and place it in the feed horn o-ring groove. Attach the OMT (item #1) to the feed horn (item #2) with the #6 hardware (item #'s 3,4,& 5). Attach two LNB's (customer provided) to the OMT with the o-rings and hardware provided with the LNB's. See figure 2. Tighten securely.

Ku-BAND - DUAL POL - PARTS LIST			
ITEM #	PART #	DESCRIPTION	QUANTITY
1	0183-272	OMT, Ku-BAND - DUAL - RECEIVE	1
2	0183-276	FEED HORN ASSEMBLY	1
3	8300-012	#6-32 x .75 S.S. STD. SCREW	6
4	8200-010	#6 LOCKWASHER	6
5	8112-001	#6-32 S.S. STD. HEX NUT	6
6	0198-120	O-RING	1

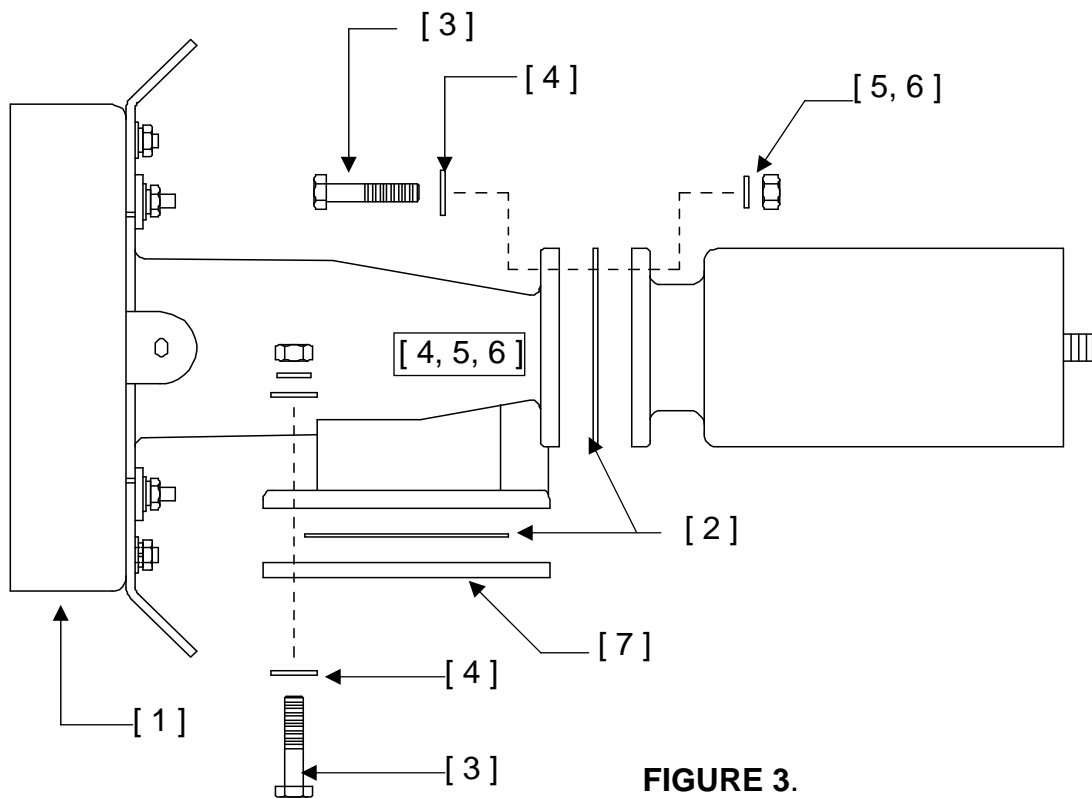

**FIGURE 2.**

**C-BAND FEED**

Attach the LNB's (customer supplied) to the feed horn flange with the 1/4" hardware and gaskets (item #'s 2 ,3,4,5,& 6) provided. See figure 3. **(SINGLE POL ONLY** - Attach the cover plate (item #7) and gasket (item #2) to the bottom of the feed horn as shown.) Tighten securely.

C-BAND - PARTS LIST			
ITEM #	PART #	DESCRIPTION	QUANTITY
1	0183-294	FEED HORN ASSEMBLY	1
2	0171-073	GASKET	1
3	8023-008	1/4-20 x 1.00 BOLT	10
4	8201-036	1/4" FLATWASHER	10
5	8202-040	1/4" LOCKWASHER	20
6	8100-005	1/4-20 HEX NUT	10



**FIGURE 3.**



**C/Ku-BAND FEED**

Attach the four feed mounting brackets to the scaler of the c/ku band feed (customer supplied) with the hardware provided. (Figure 4). Tighten securely.

C/Ku-BAND FEED PARTS LIST			
ITEM #	PART #	DESCRIPTION	QUANTITY
1	0211-405	BRACKET, FEED SUPPORT	4
2	8030-006	1/4-20 x .75 BOLT	4
3	8202-040	1/4" LOCKWASHER	4
4	8100-007	1/4-20 HEX NUT	4

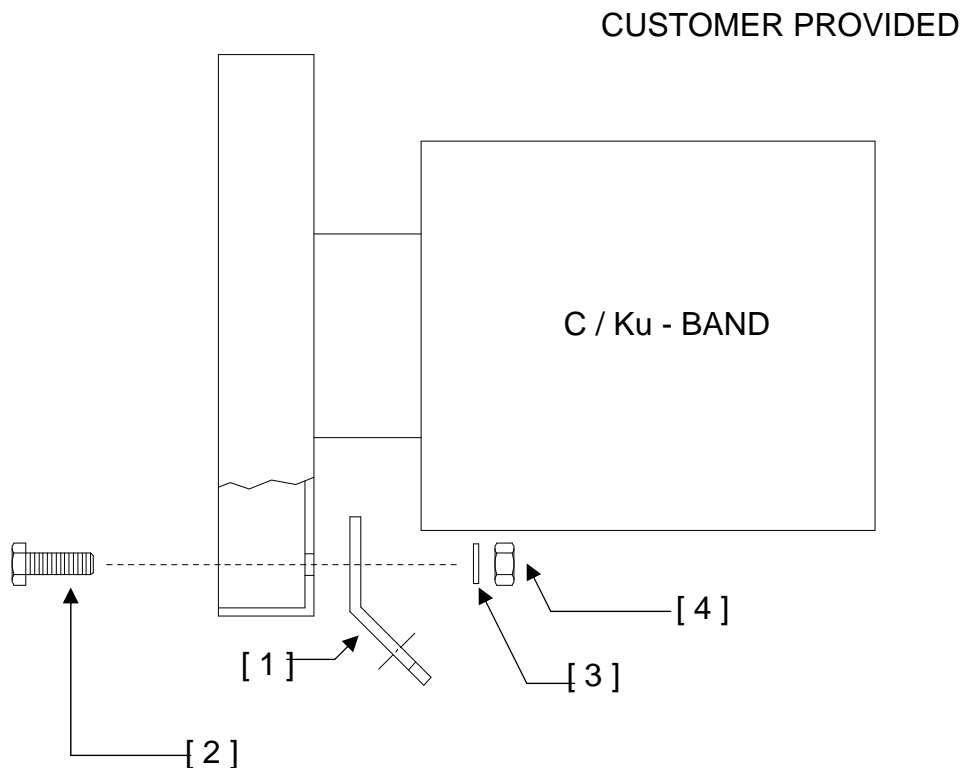

**FIGURE 4.**

FEED SYSTEM PARTS LIST TABLE 4.2			
ITEM NO.	PART NO.	DESCRIPTION	QUANTITY
1	VARIES	FEED HORN ASSEMBLY	1
2	VARIES	FEED SUPPORT ROD	4
3	8031-008	3/8-16 x 1.00 BOLT	12
4	8201-042	3/8" FLATWASHER	16
5	8202-042	3/8" LOCKWASHER	8
6	8307-006	1/2-20 x .25 SS	4
7	8102-007	3/8" HEX NUT	8
Ku-BAND SINGLE POL ONLY			
8	0156-819	FEED COVER TAB	4
9	0250-276	FEED COVER	1
10	8320-001	#8 x 1/2" TAPPING SCREW	4
11	4075-003	FEED COVER CAP	1

**4.3 FEED SUPPORT ASSEMBLY**

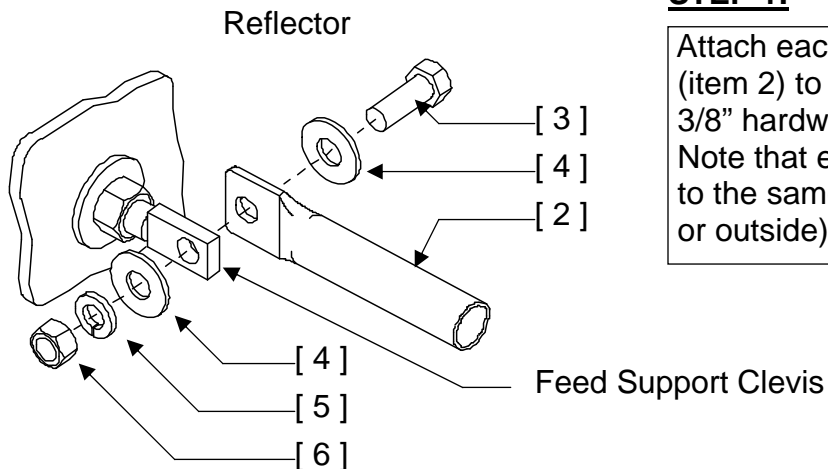

**STEP 1:**

Attach each of the feed support rods (item 2) to the feed support clevis with 3/8" hardware (items 3, 4, 5, 6). Note that each rod should be attached to the same side of the clevis - (inside or outside).

**4.4 FEED INSTALLATION**

- 1. FOCAL LENGTH** - As shown in figures 5 thru 7, attach the feed horn assembly to the four feed rods with the same 3/8" hardware as above. (For ku-band single pol only, insert the feed cover tab (item #7) between the feed horn and the 3/8" nut). Tighten the four bolts securely at this time. Check the focal length by measuring from the face of the feed horn to the reflector cover plate as shown in figure 8. If the focal length is incorrect, adjust the feed clevises in or out at the reflector surface as needed. Be sure that the clevises are adjusted equally. When the focal length is correct, tighten all feed support and clevis hardware securely. The focal lengths are: 46-7/8" for the 3.4M and 54" for the 3.7M. The F/D ratios are: .35 for the 3.4M, and .37 for the 3.7M.

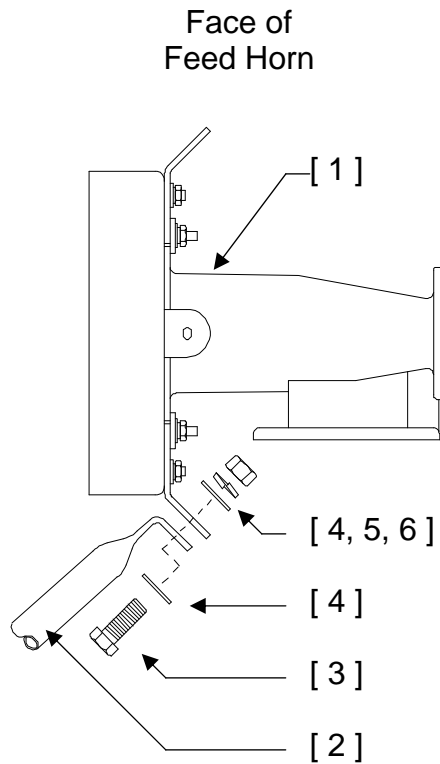

**FIGURE 5.**

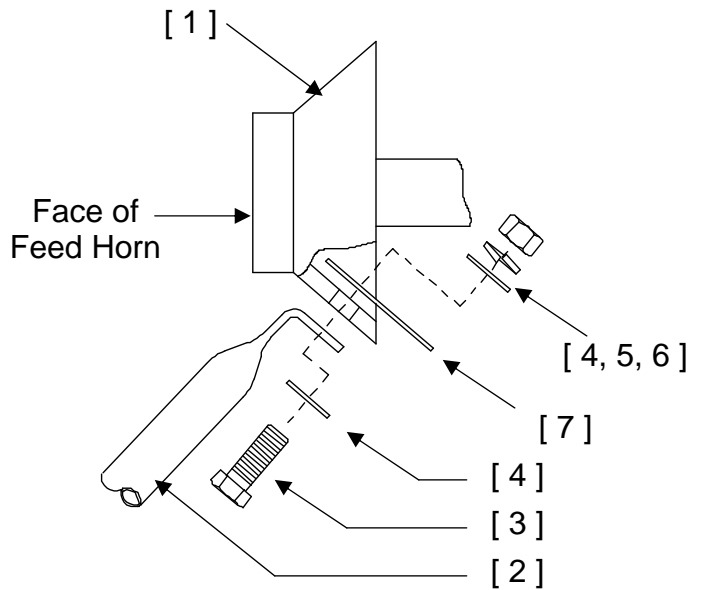

**FIGURE 6.**

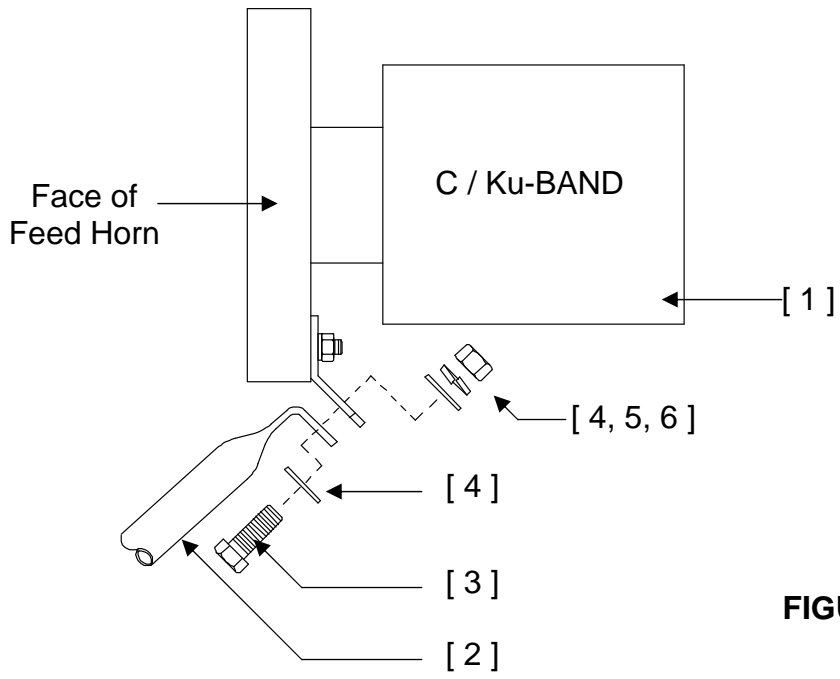

FIGURE 7.

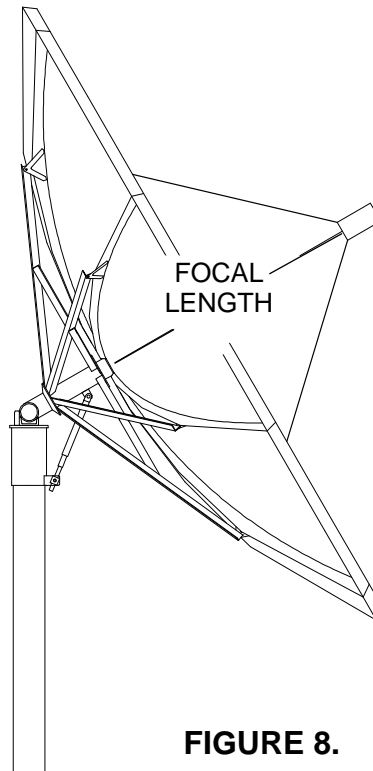

FIGURE 8.

2. **POLARITY ADJUSTMENT** - On c-band and ku-band feed systems, polarity is adjusted by loosening the feed horn bolts (see figures 9 and 10) and rotating the OMT or feed horn 90 degrees, then retighten the bolts.

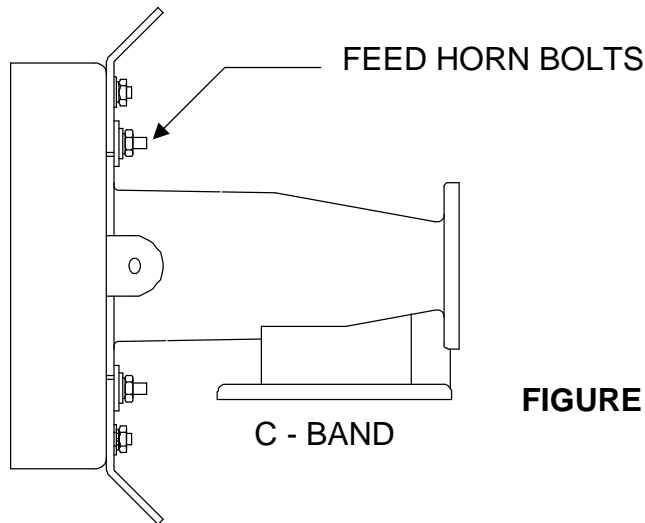

FIGURE 9.

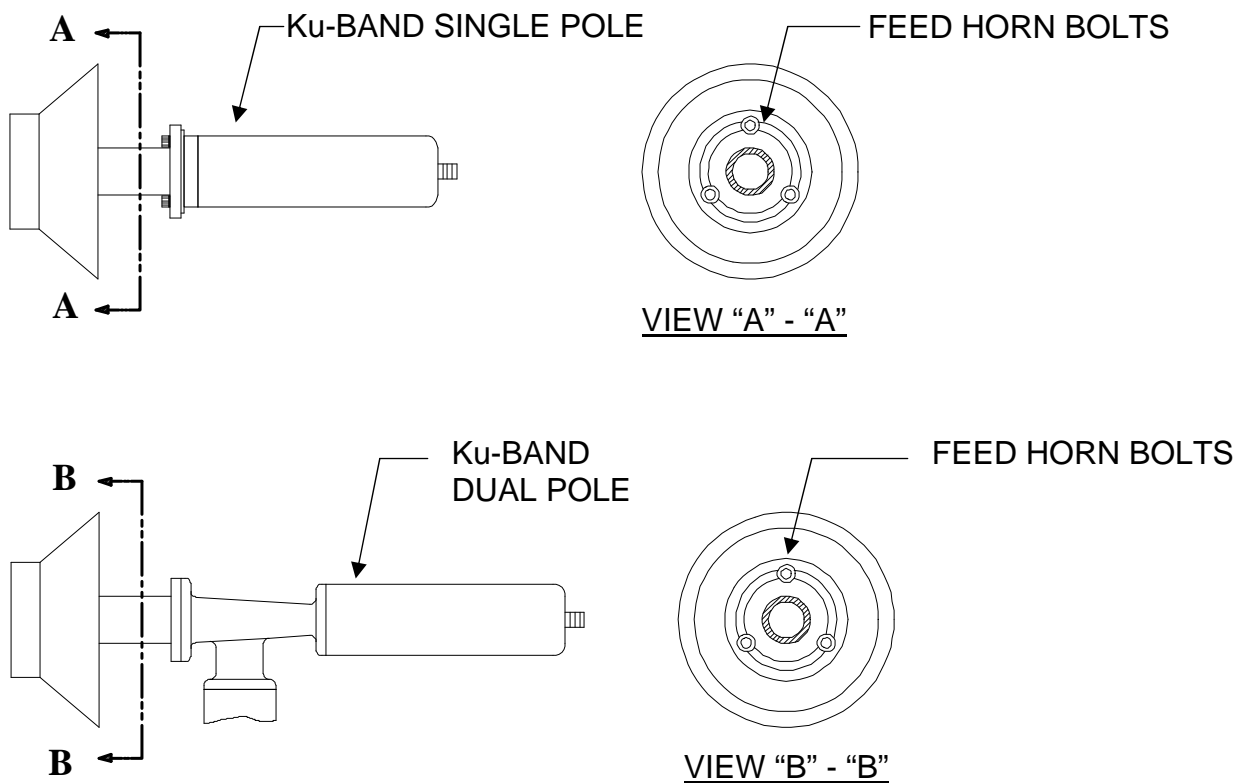
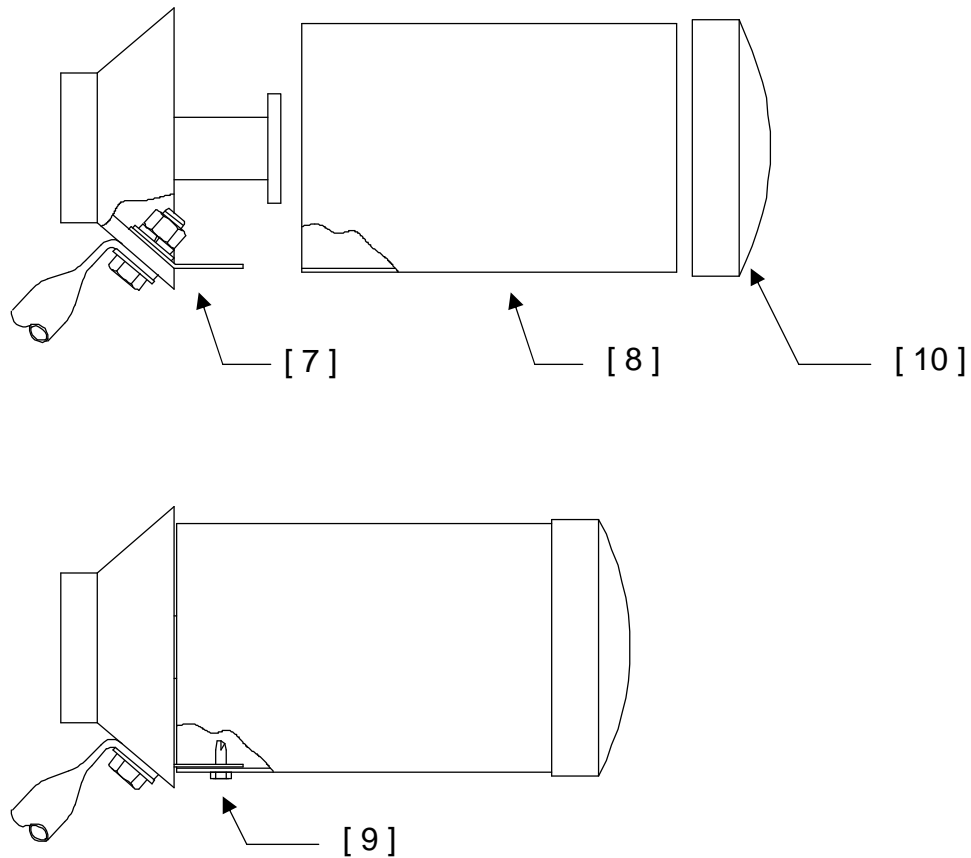

FIGURE 10.

#### 4.5 FEED COVER INSTALLATION

1. **FOR SINGLE POL KU-BAND FEED ONLY** - After completion of the feed installation, connection of the cable and polarity adjustment, bend the feed cover tabs (item #7) in and then slide the feed cover (item #8) over the tabs. Attach the cover to the tabs with the tapping screws (item # 9) and slide the cap (item #10) over the cover as shown in figure 11.



SINGLE POLE KU-BAND FEED

**FIGURE 11**

## SECTION 5 ANTENNA ALIGNMENT AND TUNING

### 5.1 ELEVATION ADJUSTMENT

1. Prior to setting the rough elevation angle, make sure that the threaded portion of the elevation rod is centered in the elevation block. Place an inclinometer on the hub as shown in figure 12.
2. The rough elevation angle is set by raising up on the lower edge of the reflector and removing the 1/2" bolt through the two struts of the elevation adjustment rod. Continue lifting up on the reflector until the desired angle is read on the inclinometer. Place the 1/2" bolt through the hole in the strut that is closest to this angle. Adjust the 3/4" nuts at the elevation block until the exact angle is read on the inclinometer.

### 5.2 AZIMUTH ADJUSTMENT

1. Make sure that all the 1/2" bolts in the canister are loose. Sweep the antenna in the azimuth until the desired signal is found. If the desired signal is not found, it may be necessary to alter the elevation angle slightly. Rotate in azimuth slowly until loss of signal is observed. Rotate the antenna in the opposite direction until the signal strengthens, and then weakens again. Set the azimuth between these two points and snug the canister.

### 5.3 FINE TUNING

1. After setting the azimuth, return to the elevation adjustment and fine tune in the same way, splitting the difference between the two points where loss of signal is first observed. Check the azimuth adjustment once more, then tighten all canister and elevation rod hardware.

### 5.4 REFLECTOR FINE ADJUSTMENT

1. As discussed in section 2, a level surface is necessary for assembly of the reflector. If a level surface is not available, the reflector may be checked for accuracy by use of strings across the aperture.
2. Use thin cord across the reflector diameter from rim to rim, at four places. One end of each string should be taped to the rim just to one side of the seam between two petals. The other end should be fastened 180 degrees opposite. All four strings should lightly touch where they cross at the center. The distance from center of the reflector (hub to plate) to the strings should be 23.22" for the 3.4M and 24" for the 3.7M.

- 3. If the reflector does not check out as described above within approximately a 1/4", reflector adjustment may be done. Identify the point on the rim that is either high or low. Loosen the four bolts on the long and short angle brace behind the radial line of the reflector. Gently push or pull on the reflector rim until it is brought into position. While one installer holds the rim, the other should tighten all the brace bolts fully. Repeat this process as required, loosening and tightening only one set of braces at a time.

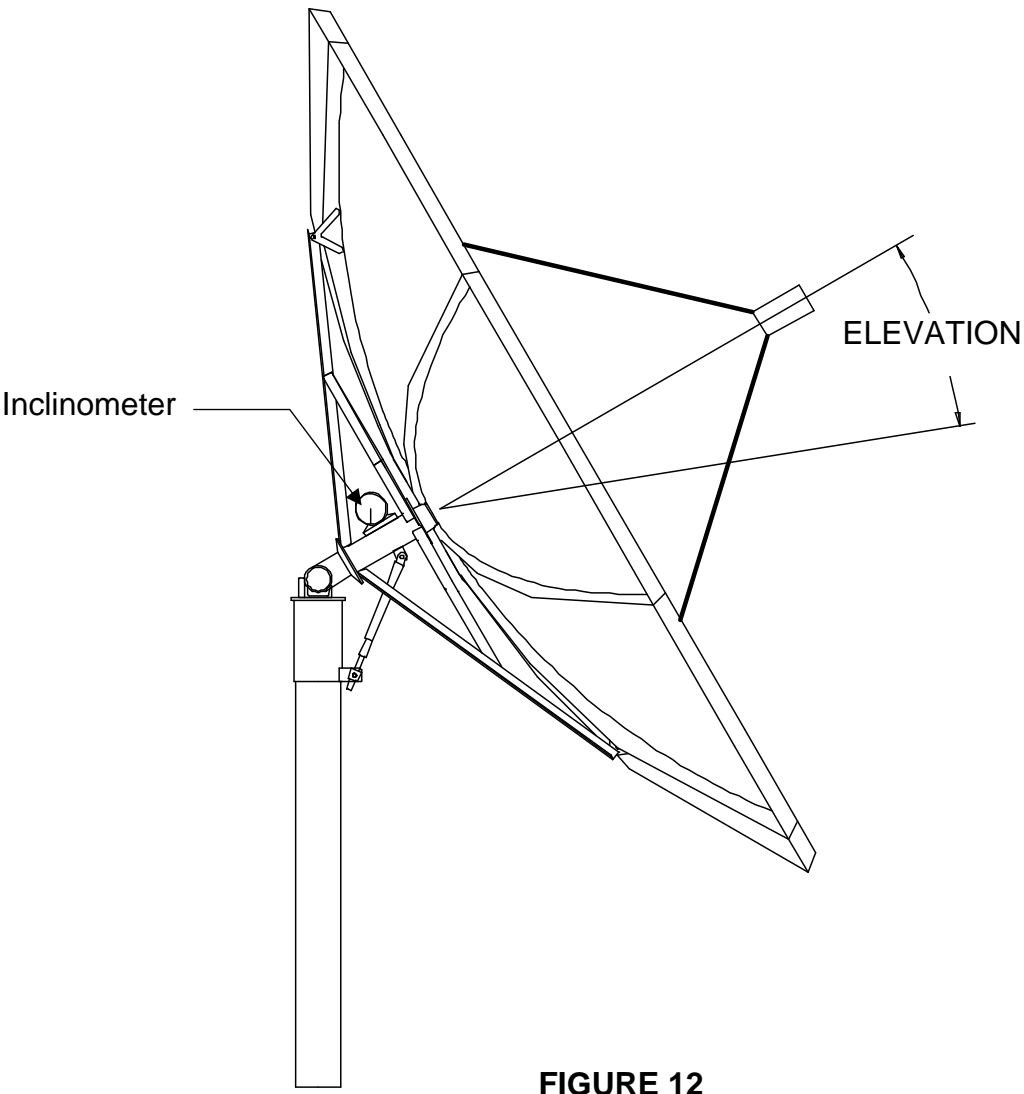

FIGURE 12